

PRECISE, PROVEN, RELIABLE

Tailor-made IBC logistics





SAFE, SECURE AND EFFICIENT

Your goals drive us

The international logistics company HOYER is a worldwide market leader in moving liquids by road, rail and sea. Wherever they may go, HOYER will get chemicals, foodstuffs, gas and mineral oil to their destinations safely and efficiently in tank containers, road tankers, flexitanks and intermediate bulk containers (IBCs).

HOYER also has numerous logistics facilities with depots, cleaning stations and workshops. 115 representative offices and more than 6,000 employees throughout the world ensure a reliable and smooth transport process. HOYER is organised in business units that cover a variety of product and service areas and thereby always guarantee the right logistical solution for every requirement.

CUSTOMISED IBC SOLUTIONS

IBCs are an ideal alternative between a drum and a tanker to transport liquid products. The range of IBC services HOYER offers includes fleet management, leasing, transport, cleaning, maintenance and repair. HOYER provides all these services individually, or combines them together to form customised services packages – making use of a European network, comprehensive communications

systems and an efficient infrastructure. The majority of the fleet consists of standardised IBC types, but a large number of small custom-made containers with the required accessories is also available. The IBCs have volumes from 500 to 1,100 litres and are available in various grades of stainless steel as well as with dangerous goods approval.

VOLUMES
FROM 500 TO
1,100 LITRES

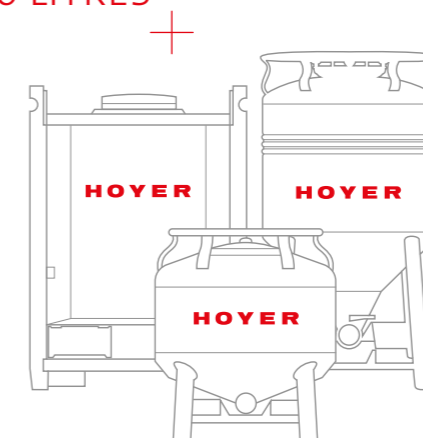

OUR SERVICES COMBINED BY YOU

HOYER offers a comprehensive range of services, not only for its own IBCs but also for those of its customers. They can make use of fleet management, leasing, transport, cleaning, maintenance and repair, individually or combined, all the way to full service – depending on the need. HOYER offers maximum flexibility with individually customised IBC packages. This is based on both its wide-ranging network and its steadily growing IBC fleet. HOYER undertakes the on-schedule planning of IBC capacities, careful cleaning and maintenance, or complex transport logistics – thus enabling companies in the chemicals and foodstuffs industries to concentrate fully on their core business.



HIGHEST LEVEL OF FLEXIBILITY

Our services



FLEET MANAGEMENT

HOYER undertakes both operational and strategic container management: from inventory management and needs analysis to container control and monitoring and technical management. IT systems designed specifically for the purpose give a transparent graphic display of container inventories and flows of goods within the delivery chain, even across corporate boundaries – with clearly recognisable benefits.

- Shortening downtimes
- Overview of the IBC locations
- Optimising fleet size
- Increasing flexibility



LEASING

Further technical development of the company's own IBC fleet is paramount for HOYER, to meet the increasing and diverse needs for the transport and storage of a wide variety of goods. Accordingly, a wide spectrum of different IBC types made of stainless steel is available, together with the necessary accessories. For example, HOYER offers small heatable containers as well as aseptic IBCs which enable the low-germ transport and storage of sensitive products.

- Leasing of various IBC types and mini pressure tanks
- Flexible term of leasing – a few days to several years
- Available with dangerous goods approval
- Volumes from 500 to 1,100 litres
- Various grades of stainless steel
- Agitators as additional equipment



TRANSPORT

The transport of sensitive high-value products in an IBC depends on careful handling from loading to unloading. HOYER maintains high standards and has access to know-how acquired over many decades. The aim is to control container flows in an optimum, demand-based way. The main emphasis in this respect is on efficient logistics.

- Worldwide implementation
- Competitive freight rates
- Reverse logistics
- Reliable execution



CLEANING

IBCs are cleaned in a product-specific way. SQAS-audited cleaning plants throughout the world and exceptionally well-trained staff ensure the highest hygiene standards and guarantee clean containers. Cleaning is offered for both HOYER's IBCs and customers' own IBCs.

- Product-specific cleaning, including certificates
- Uniformly standardised cleaning processes
- Tests to determine sterility on request
- Environmentally correct disposal of product residues



MAINTENANCE AND REPAIR

HOYER offers a worldwide, highly-efficient service network to provide technical services. All the depots operate in accordance with the regulations of the IBC approval authorities, and implement the HOYER Group's high quality standards. All the services are also offered for customers' own containers.

- Statutorily prescribed periodic inspections
- Tests of electrical elements to prevent accidents
- Technical support at the depots and on the spot
- Maintenance and modification of IBCs

WITH SUSTAINABLE EXPERTISE

Our commitment for your success

Our IBC logistics provides more: the safe, secure transport of challenging liquid goods, for example, and many years of expertise in handling dangerous goods, which we combine with the highest requirements regarding climate-friendly logistics solutions that protect the environment. You can profit from the reliability and strong performance of a leading international logistics supplier. Use our wide range of quickly available, reusable IBCs made from durable stainless steel to carry your business forward.

- Worldwide network with qualified service on the spot
- Tailor-made fleet management to increase flexibility and efficiency
- A wide variety of equipment for specific product requirements
- Technical expertise and customised advice
- Many years of experience in IBC management

WORLDWIDE PRESENCE

International sites

GERMANY

HOYER GmbH

Head Office

Wendenstrasse 414-424

20537 Hamburg | Germany

Phone +49 40 21044 0

FRANCE

HOYER France S.A.S. (Rouen)

5, Boulevard du Midi

76107 Rouen Cedex 1 | France

Phone +33 2 32 81 63 10

GREAT BRITAIN

HOYER UK Ltd.

517 Leeds Road

HD2 1YJ Huddersfield | Great Britain

Phone +44 1484 548 221

ITALY

HOYER Italia S.r.l.

Via Dogana, 2

21052 Busto Arsizio (Varese) | Italy

Phone +39 0331 38 55 11

POLAND

HOYER Polska Sp. z o.o.

ul. Rozdzienska 41

40-382 Katowice | Poland

Phone +48 32 786 180 0

THE NETHERLANDS

HOYER Nederland B.V.

Oude Maasweg 50

3197 KJ Botlek RT | The Netherlands

Phone +31 10 2953 333

CHINA

Multilog Industry (Shanghai) Co., Ltd.

10/F 01-03, Finance Square

333 Jiu Jiang Road

Shanghai | P. R. China, 200001

Phone +8621 6351 9641

USA

HOYER Global (USA), Inc.

2100 Space Park Drive, Suite 200

Houston, TX 77058 | USA

Phone + 1 281 436 1121